

# CRAWLER CARRIER

**SC-156**      **DA**  
**DB**  
**DC**  
**DD**

**(WITH MITSUBISHI GM131 OHV ENGINE)**

# PARTS LIST

**SABRE ITALIA** 

Tel. 0444 977655 – Fax 0444 977200  
[www.sabreitalia.com](http://www.sabreitalia.com) – [info@sabreitalia.com](mailto:info@sabreitalia.com)

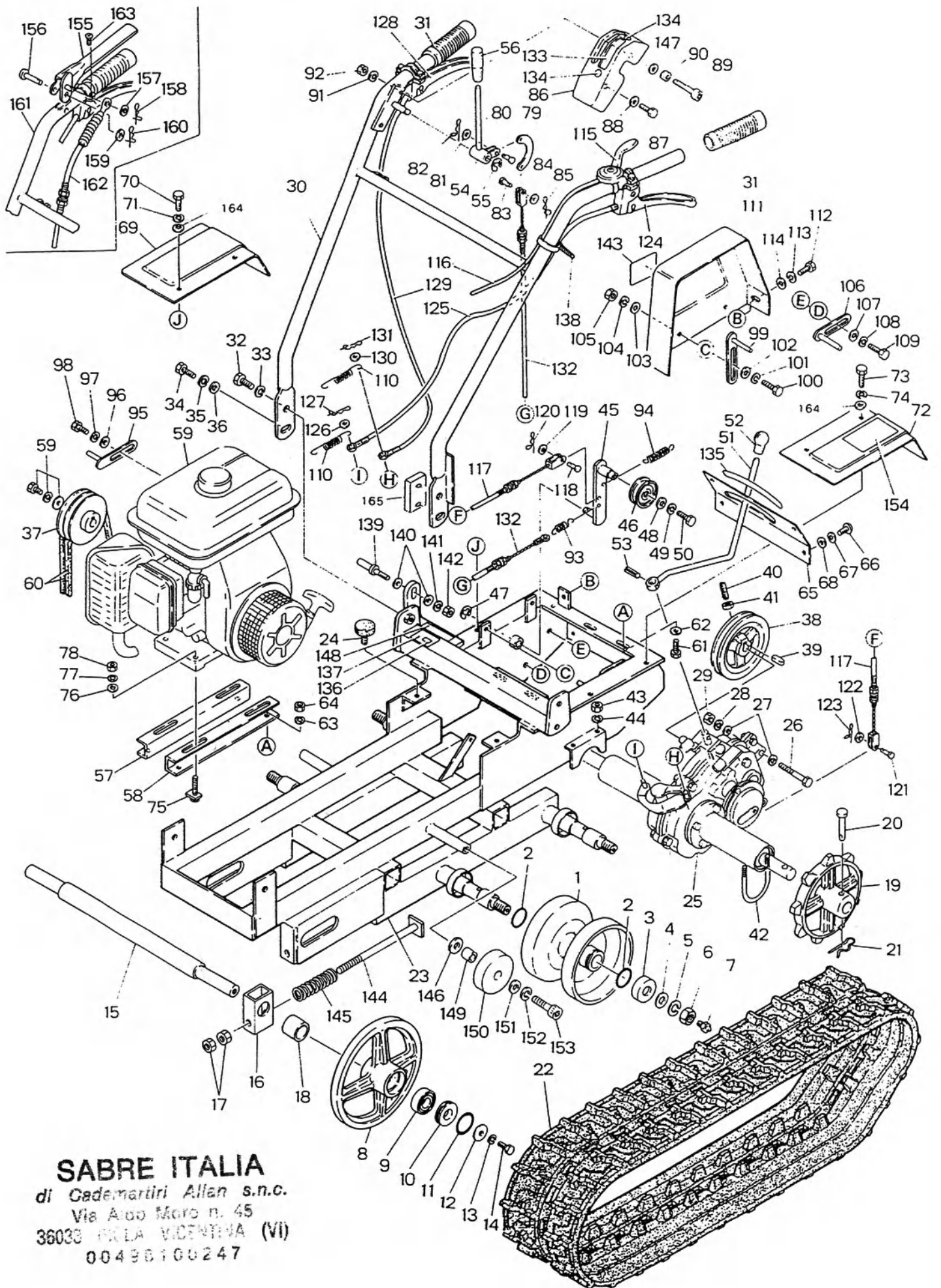

**SABRE ITALIA**  
 di Cademartiri Allan s.n.c.  
 Via Aldo Moro n. 45  
 36038 ISOLA VICENTINA (VI)  
 00496100247

DWG NO.	CODE NO.	PART NAME	STANDARD	QTY FOR DA	QTY FOR DB	QTY FOR DC	QTY FOR DD	REMARKS
1- 1	6011550000	FREE WHEEL		4	4	4	4	
1- 2	0052100360	O-RING	P36	8	8	8	8	
1- 3	6061591000	FREE WHEEL DUST PROTECTING CAP		4	4	4	4	
1- 4	0026100020	FLAT WASHER	M20	4	4	4	4	
1- 5	0027100020	SPRING WASHER	M20	4	4	4	4	
1- 6	0020200020	NUT	M20 x P 1.5	4	4	4	4	
1- 7	0060660000	GREASE NIPPLE	1/4-28UNF A	4	4	4	4	
1- 8	6011530000	FRONT WHEEL		2	2	2	2	
1- 9	0040146005A	BEARING	B B6005(2NS)	4	4	4	4	
1- 10	6016511000	FRONT WHEEL DUST PROTECTING CAP		4	4	4	4	
1- 11	0052300450	O-RING	G45	4	4	4	4	
1- 12	6030201000	FLAT WASHER		2	2	2	2	
1- 13	0027100010	SPRING WASHER	M10	2	2	2	2	
1- 14	0010101020	BOLT	M10x20	2	2	2	2	
1- 15	60700120300	SHAFT, FRONT		1	1	1	1	
1- 16	60700120200	HOLDER		2	2	2	2	
1- 17	0020100012	NUT	M12	4	4	4	4	
1- 18	60700120400	COLLAR , FRONT		2	2	2	2	
1- 19	6491020000	SPROCKET 9T		2	2	2	2	
1- 20	0031319803	PLAIN PIN	Ø 10 x 60 (54)	2	2	2	2	
1- 21	0031100010	PIN WITH STOPPER	Ø 10 x Ø 2	2	2	2	2	
1- 22	6496203000	RUBBER CRAWLER	180 <sup>W</sup> x34 <sup>L</sup> x 60 <sup>P</sup>	2	2	2	2	
1- 23	60701020010	CHASSIS		1	1	1	1	
1- 24	6376512000	RUBBER		2	2	2	2	
1- 25	6496011002	TRANSMISSION ASSY	FT15	1	1	1	1	
1- 26	0100000060	BOLT	M10 x 65	1	1	1	1	
1- 27	0026100010	FLAT WASHER	M10	2	2	2	2	
1- 28	0027100010	SPRING WASHER	M10	1	1	1	1	
1- 29	0020100010	NUT	M10	1	1	1	1	
1- 30	60706020000	HANDLE		1		1		
1- 31	6066030000	GRIP	Ø 26	2	2	2	2	
1- 32	0010101025	BOLT	M10 x 25	2	2	2	2	
"	0010101025	SPRING WASHER	M10 x 25	1	1	1	1	FOR HONDA GX 110,GX 120
"	0010101065	BOLT	M10 x 65	1	1	1	1	" "
1- 33	0027100010	SPRING WASHER	M10	2	2	2	2	

DWG NO.	CODE NO.	PART NAME	STANDARD	QTY FOR DA	QTY FOR DB	QTY FOR DC	QTY FOR DD	REMARKS
1 - 34	0010101225	BOLT	M12 x 25	2	2	2	2	
"	0010101225	"	M12 x 25	1	1	1	1	FOR HONDA ENGINE GX110, GX120
"	0010101265	"	M12 x 65	1	1	1	1	" "
1 - 35	0027100012	SPRING WASHER	M12	2	2	2	2	
1 - 36	0026100012	FLAT WASHER	M12	2	2	2	2	
1 - 37	6494300000	ENGINE PULLEY		1	1	1	1	FOR MITSUBISHI G131 ENGINE
"	6494300000	" "		1	1	1	1	FOR SHIBAURA GEF15RE ENGINE
"	6494300010	" "		1		1		FOR SHIBAURA GEF18RE ENGINE
"	6494300000	" "		1	1	1	1	FOR ROBINE EY152B ENGINE
"	6494300000	" "		1		1		FOR HONDA GX110 ENGINE
"	6494300000	" "		1	1	1	1	FOR HONDA GX120 ENGINE
"	6494300000	" "		1	1	1	1	FOR KAWASAKI FG150GX ENGINE
1 - 38	6492300010	INPUT AXLE PULLEY		1	1	1	1	
1 - 39	0300000015	KEY	5 x 5 x 20	1	1	1	1	
1 - 40	0160000830	BOLT	M 8 x 30	1	1	1	1	
1 - 41	0020100008	NUT	M8	1	1	1	1	
1 - 42	6492070000	U-BOLT		2	2	2	2	
1 - 43	0020100008	NUT	M8	4	4	4	4	
1 - 44	0027100008	SPRING WASHER	M8	4	4	4	4	
1 - 45	6492280000	TRACTION TENSION ARM ARM		1	1	1	1	
1 - 46	6066110000	TENSION PULLEY	55T 1	1	1	1	1	
1 - 47	0036800012	E-RING	E12	1	1	1	1	
1 - 48	6066070000	WASHER		1	1	1	1	
1 - 49	0027100006	SPRING WASHER	M6	1	1	1	1	
1 - 50	0010100616	BOLT	M6 X 16	1	1	1	1	
1 - 51	6492330001	CHANGE LEVER		1	1	1	1	
1 - 52	6006030000	GRIP	Ø 10 BLACK	1	1	1	1	
1 - 53	0030300525	SPRING PIN	Ø 5 X 25	1	1	1	1	
1 - 54	6492330010	TRACTION LEVER		1		1		
1 - 55	0036800012	E-RING	E12	1		1		
1 - 56	6066030010	GRIP	Ø 9.5 BLACK	1		1		
1 - 57	6744290150	ENGINE BASE		1	1	1	1	FOR MITSUBISHI GM131 ENGINE
"	6492290000	ENGINE BASE (R)		1	1	1	1	FOR SHIBAURA GEF15RE ENGINE
"	6492290000	ENGINE BASE (R)		1		1		FOR SHIBAURA GEF18RE ENGINE
"	6492290000	ENGINE BASE (R)		1	1	1	1	FOR ROBINE EY-152B ENGINE

DWG NO.	CODE NO.	PART NAME	STANDARD	QTY FOR DA	QTY FOR DB	QTY FOR DC	QTY FOR DD	REMARKS
1 - 57	6744340100	ENGINE BASE		1		1		FOR HONDA GX110 ENGINE
"	6744340100	" "		1	1	1	1	FOR HONDA GX120 ENGINE
"	6492290000	ENGINE BASE (R)		1	1	1	1	FOR KAWASAKI FG150 ENGINE
1 - 58	6744290150	ENGINE BASE		1	1	1	1	FOR MITSUBISHI GM131 ENGINE
"	6492290010	ENGINE BASE (L)		1	1	1	1	FOR SHIBAURA GEF15RE ENGINE
"	6492290010	ENGINE BASE (L)		1		1		FOR SHIBAURA GEF18RE ENGINE
"	6492290010	ENGINE BASE (L)		1	1	1	1	FOR ROBIN EY-152B ENGINE
"	6744340100	ENGINE BASE		1		1		FOR HONDA GX110 ENGINE
"	6744340100	ENGINE BASE		1	1	1	1	FOR HONDA GX120 ENGINE
"	6492290010	ENGINE BASE (L)		1	1	1	1	FOR KAWASAKI FG150GX ENGINE
1 - 59	60702260100	ENGINE	MITSUBISHI GM131	1	1	1	1	
"	6746001000	"	SHIBAURA GEF15RE	1	1	1	1	
"	6066001002	"	SHIBAURA GEF18RE	1		1		
"	6756002000	"	ROBIN E Y - 152 B	1	1	1	1	
"	6756006000	"	HONDA G X 110	1		1		
"	60702260000	"	HONDA G X 120	1	1	1	1	
"	6746008000	"	KAWASAKI F G 150 G X	1	1	1	1	
1 - 60	0080300035	V-BELT	B35	1	1	1	1	FOR MITSUBISHI GM131 ENGINE
"	0080300035	"	B35	1	1	1	1	FOR SHIBAURA GEF15RE ENGINE
"	0080300035	"	B35	1		1		FOR SHIBAURA GEF18RE ENGINE
"	0080300035	"	B35	1	1	1	1	FOR ROBIN EY-152B ENGINE
"	0080300035	"	B35	1		1		FOR HONDA GX110 ENGINE
"	0080300036	"	B36	1	1	1	1	FOR HONDA GX120 ENGINE
"	0080300035	"	B35	1	1	1	1	FOR KAWASAKI FG150GX ENGINE
1 - 61	0010100820	BOLT	M8 x 20	4	4	4	4	
1 - 62	0026100008	FLAT WASHER	M8	4	4	4	4	
1 - 63	0027100008	SPRING WASHER	M8	4	4	4	4	
1 - 64	0020100008	NUT	M8	4	4	4	4	
1 - 65	6492650000	GUIDE PLATE CHANGE LEVER		1	1	1	1	
1 - 66	0015100616	BOLT	M6 x 16	4	4	4	4	
1 - 67	0027100006	SPRING WASHER	M6	4	4	4	4	
1 - 68	0026100006	FLAT WASHER	M6	4	4	4	4	
1 - 69	6492350000	FENDER (R)		1	1	1	1	
1 - 70	0010100816	BOLT	M8 x 16	2	2	2	2	
1 - 71	0027100008	SPRING WASHER	M8	2	2	2	2	

DWG NO.	CODE NO.	PART NAME	STANDARD	QTY FOR DA	QTY FOR DB	QTY FOR DC	QTY FOR DD	REMARKS
1 - 72	6492350010	FENDER (L)		1	1	1	1	
1 - 73	0010100816	BOLT	M8 x 16	2	2	2	2	FOR SHIBAURA GEF15RE/GEF18R
"	0010100816	"	M8 x 16	1	1	1	1	" "
"	0010100820	"	M8 x 20	1	1	1	1	
1 - 74	0027100008	SPRING WASHER	M8	2	2	2	2	
1 - 75	6462076010	WASHERHEAD BOLT (ENGINE)		4	4	4	4	
"	6332072010	WASHERHEAD BOLT		4	4	4	4	FOR HONDA GX120
1 - 76	0026100008	FLAT WASHER	M8	4	4	4	4	
1 - 77	0027100008	SPRING WASHER	M8	4	4	4	4	
1 - 78	0020100008	NUT	M8	4	4	4	4	
1 - 79	6152400000	ROD		1		1		
1 - 80	6066080000	FLAT HEAD PIN	Ø 6 x 19 (15)	1		1		
1 - 81	0026100006	FLAT WASHER	M6	1		1		
1 - 82	0031199006	PIN WITH STOPPER	Ø 6	1		1		
1 - 83	6066080000	FLAT HEAD PIN	Ø 6 x 19 (15)	1		1		
1 - 84	0026100006	FLAT WASHER	M6	1		1		
1 - 85	0031199006	PIN WITH STOPPER	Ø 6	1		1		
1 - 86	2410360150	CLUTCH COVER		1		1		
1 - 87	0010100612	BOLT	M6 x 12	1		1		
1 - 88	0026100006	FLAT WASHER	M6	1		1		
1 - 89	0010700625	SOCKET BOLT	M6 x 25	1		1		
1 - 90	0020100006	NUT	M6	1		1		
1 - 91	0027100006	SPRING WASHER	M6	1		1		
1 - 92	0020100006	NUT	M6	1		1		
1 - 93	6172105000	SPRING		1	1	1	1	
1 - 94	6492100000	SPRING		1	1	1	1	
1 - 95	6062370010	BELT HOLDER		1	1	1	1	
1 - 96	0026100008	FLAT WASHER	M8	1	1	1	1	
1 - 97	0027100008	SPRING WASHER	M8	1	1	1	1	
1 - 98	0010100816	BOLT	M8 x 16	1	1	1	1	
1 - 99	6062370010	BELT HOLDER		1	1	1	1	
1 - 100	0010100825	BOLT	M8 x 25	1	1	1	1	
1 - 101	0027100008	SPRING WASHER	M8	1	1	1	1	
1 - 102	0026100008	FLAT WASHER	M8	1	1	1	1	
1 - 103	6102040000	WASHER		1	1	1	1	

DWG NO.	CODE NO.	PART NAME	STANDARD	QTY FOR DA	QTY FOR DB	QTY FOR DC	QTY FOR DD	REMARKS
1 - 104	0027100008	SPRING WASHER	M8	1	1	1	1	
1 - 105	0020100008	NUT	M8	1	1	1	1	
1 - 106	6062370010	BELT HOLDER		2	2	2	2	
1 - 107	0026100008	FLAT WASHER	M8	2	2	2	2	
1 - 108	0027100008	SPRING WASHER	M8	2	2	2	2	
1 - 109	0010100816	BOLT	M8 x 16	2	2	2	2	
1 - 110	6062104010	SPRING		2	2	2	2	
1 - 111	6496520000	BELT COVER		1	1	1	1	
1 - 112	0010100812	BOLT	M8 x 12	2	2	2	2	
1 - 113	0027100008	SPRING WASHER	M8	2	2	2	2	
1 - 114	6102040000	WASHER		2	2	2	2	
1 - 115	6066132000	THROTTLE LEVER		1	1	1	1	
1 - 116	6066043000	THROTTLE WIRE		1	1	1	1	FOR MITSUBISHI GM131 ENGINE
"	6496040000	" "		1	1	1	1	FOR SHIBAURA GEF15RE ENGINE
"	6496040000	" "						FOR SHIBAURA GEF18RE ENGINE
"	7006044000	" "						FOR ROBIN EY-152B ENGINE
"	6066043000	" "						FOR HONDA GX110 ENGINE
"	6066043000	" "						FOR HONDA GX120 ENGINE
"	6496040000	" "		1	1	1	1	FOR KAWASAKI FG150GX ENGINE
1 - 117	6496040010	BRAKE WIRE		1	1	1	1	
1 - 118	6066080000	PIN	Ø 6 x 19 (15)	1	1	1	1	
1 - 119	0026100006	FLAT WASHER	M6	1	1	1	1	
1 - 120	0031199006	PIN WITH STOPPER	Ø 6	1	1	1	1	
1 - 121	6066080000	PIN	Ø 6 x 19 (15)	1	1	1	1	
1 - 122	0026100006	FLAT WASHER	M6	1	1	1	1	
1 - 123	0031199006	PIN WITH STOPPER	Ø 6	1	1	1	1	
1 - 124	6496130000	CLUTCH LEVER	IN ACCIAIO	1		1		
"	6492999000	CLUTCH LEVER	IN PLASTICA		1		1	
1 - 125	6496040020	SIDE CLUTCH WIRE		1	1	1	1	
1 - 126	0026100006	FLAT WASHER	M6	1	1	1	1	
1 - 127	0031199006	PIN WITH STOPPER	Ø 6	1	1	1	1	
1 - 128	6496130000	CLUTCH LEVER	IN ACCIAIO	1		1		
"	6492999000	CLUTCH LEVER	IN PLASTICA		1		1	
1 - 129	6496040020	SIDE CLUTCH WIRE		1	1	1	1	
1 - 130	0026100006	FLAT WASHER	M6	1	1	1	1	
1 - 131	0031199006	PIN WITH STOPPER	Ø 6	1	1	1	1	

DWG NO.	CODE NO.	PART NAME	STANDARD	QTY FOR DA	QTY FOR DB	QTY FOR DC	QTY FOR DD	REMARKS
1 - 132	6496040030	TRACTION TENSION WIRE		1			1	
1 - 133	6496020000	TRACTION MARK		1			1	
1 - 134	6496020030	INPUT MARK		2			2	
1 - 135	6496020010	SHIFT MARK		1	1	1	1	
1 - 136	4226024001	DIRECTION MARK		1	1	1	1	
1 - 137	6316026000	REFUELING MARK		1	1	1	1	
1 - 138	2499110030	BAND		5	5	5	5	
"	2499110030	"		6	6	6	6	FOR MITSUBISHI GM131 ENGINE
1 - 139	6062070010	HOOK SCREW		1	1	1	1	
1 - 140	0026100012	FLAT WASHER	M12	2	2	2	2	
1 - 141	0027100012	SPRING WASHER	M12	1	1	1	1	
1 - 142	0020100012	NUT	M12	1	1	1	1	
1 - 143	6746030000	MARK "SATO"		1	1	1	1	
1 - 144	60700120000	CRAWLER EXTENSION	ROD	2	2	2	2	
1 - 145	60700120100	SPRING		2	2	2	2	
1 - 146	0026100014	FLAT WASHER	M14	2	2	2	2	
1 - 147	6066070000	WASHER		1		1		
1 - 148	6066020032	MARK		1	1	1	1	
1 - 149	6491040600	COLLAR		2	2	2	2	
1 - 150	6376520000	ROLLING WHEEL	Ø 78	2	2	2	2	
1 - 151	0026100014	FLAT WASHER	M14	2	2	2	2	
1 - 152	0027100014	SPRING WASHER	M14	2	2	2	2	
1 - 153	0010701445	SCREW CAP	M14 x 45	2	2	2	2	
1 - 154	60706560100	MARK		1	1	1	1	
1 - 155	6496J30600	CLUTCH LEVER			1		1	
1 - 156	0031310640	PIN	Ø 6 x 43 (40)		1		1	
1 - 157	0026100006	FLAT WASHER	M6		1		1	
1 - 158	0031199006	PIN WITH STOPPER	Ø 6		1		1	
1 - 159	0026100006	FLAT WASHER	M6		1		1	
1 - 160	0031199006	PIN WITH STOPPER	Ø 6		1		1	
1 - 161	6494310600	HANDLE (DEADMAN)			1		1	
1 - 162	6496040600	TRACTION WIRE (DEADMAN)			1		1	
1 - 163	0100000192	BOLT	M6 x 25		2		2	
1 - 164	0026100008	FLAT WASHER	M8	4	4	4	4	
1 - 165								(FOR HONDA ENGINE)



SC156DA, DB, DC, DD

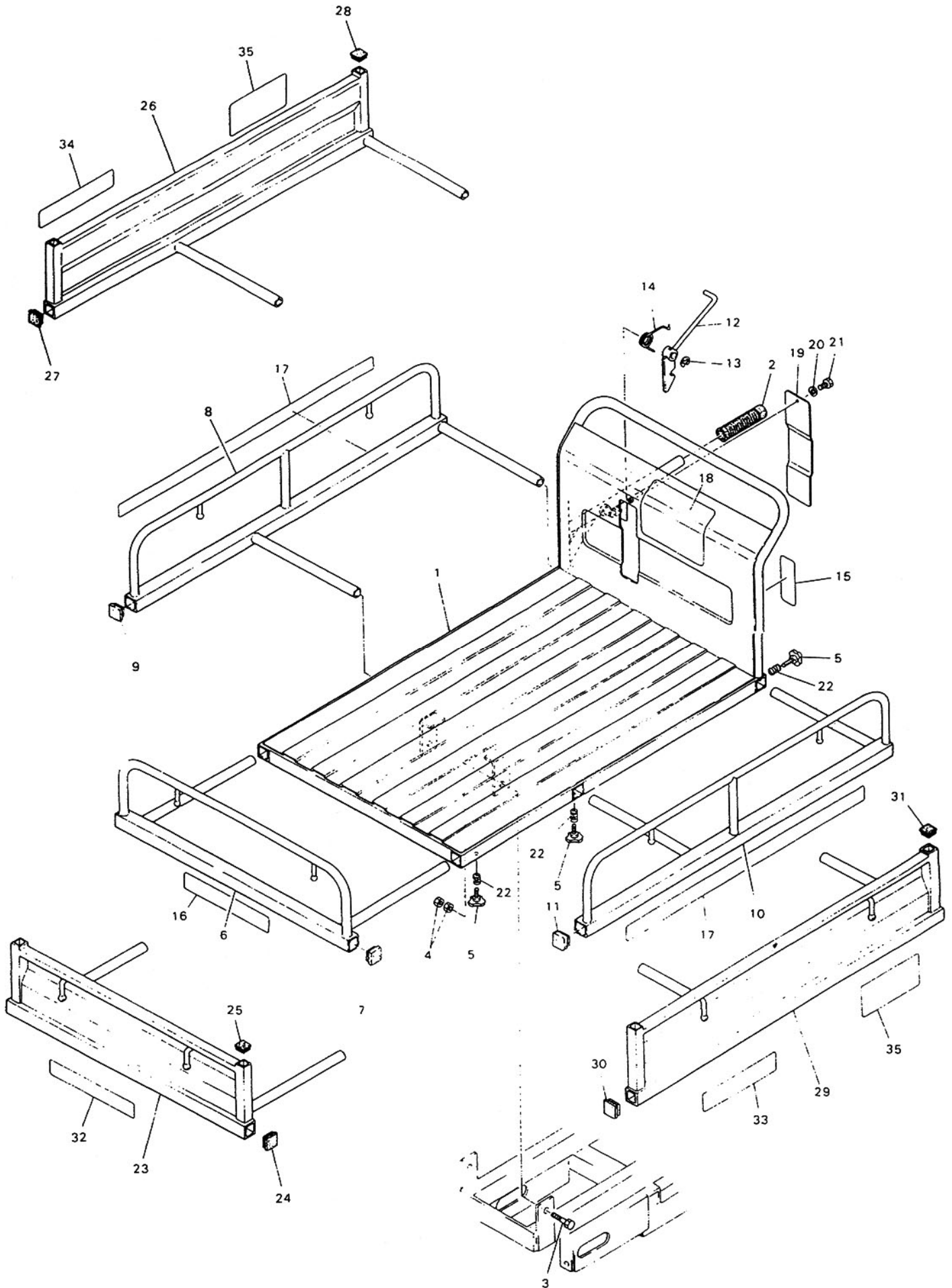

DWG NO.	CODE NO.	PART NAME	STANDARD	QTY FOR DA	QTY FOR DB	QTY FOR DC	QTY FOR DD	REMARKS
2- 1	6494600000	DECK		1	1	1	1	
2- 2	7276030000	GRIP	Ø 25. 4	1	1	1	1	
2- 3	0010111445	BOLT	M14 x 45 Half Thread (S45C)	2	2	2	2	
2- 4	0020100014	NUT	M14	4	4	4	4	
2- 5	0100000108	KNOB BOLT	M8 x 15	6	6	6	6	
2- 6	6492630000	FRONT WALL		1	1			
2- 7	6056210000	RUBBER CAP	32 x 32 x t 1.6	2	2			
2- 8	6492630010	SIDE WALL (R)		1	1			
2- 9	6056210000	RUBBER CAP	32 x 32 x t 1.6	2	2			
2- 10	6492630020	SIDE WALL (L)		1	1			
2- 11	6056210000	RUBBER CAP	32 x 32 x t 1.6	2	2			
2- 12	6062393000	DUMP HOOK		1	1	1	1	
2- 13	0036800012	E-RING	E12	1	1	1	1	
2- 14	6062104040	SPRING		1	1	1	1	
2- 15	6316391000	REFLECTING STICKER		2	2	2	2	
2- 16	6746060010	CAPACITY LABEL		1	1			
2- 17	60706560000	MARK "156DB"	S C 156 D B	1	2			
"	60716560000	MARK "156DA"	S C 156 D A	2				
2- 18	6386020021	MARK "GORIKI"		1	1	1	1	
2- 19	6494990000	COVER		1	1	1	1	
2- 20	0027100006	SPRING WASHER	M6	1	1	1	1	
2- 21	0010100612	BOLT	M6 x 12	1	1	1	1	
2- 22	6492100020	SPRING KNOB BOLT		6	6	6	6	
2- 23	60725220000	FRONT AUX. DECK				1	1	
2- 24	6056210000	RUBBER CAP	For Sq. Pipe 32 x 32 x t 1.6			2	2	
2- 25	6056210010	RUBBER CAP	For Sq. Pipe 25 x 25 x t 1.6			2	2	
2- 26	60725220100	AUX. DECK (R)				1	1	
2- 27	6056210000	RUBBER CAP	For Sq. Pipe 32 x 32 x t 1.6			2	2	
2- 28	6056210010	RUBBER CAP	For Sq. Pipe 25 x 25 x t 1.6			2	2	
2- 29	60725220200	AUX. DECK (L)				1	1	
2- 30	6056210000	RUBBER CAP	For Sq. Pipe 32 x 32 x t 1.6			2	2	
2- 31	6056210010	RUBBER CAP	For Sq. Pipe 25 x 25 x t 1.6			2	2	
2- 32	6746060010	CAPACITY LABEL				1	1	
2- 33	60726560000	LABEL (MODEL)	S C 156 D C			1		
"	60736560000	" ( " )	S C 156 D D				1	
2- 34	60726560100	MARK (SATO MFG)				1	1	
2- 35	61106560200	CORPORATE PATTERN				2	2	

# Trasmissione FT15 x SC-151, SC-155, SC-156

BLIND CAP 18<sup>t</sup> x 5<sup>t</sup> - 2  
 BLIND CAP 16<sup>t</sup> x 7<sup>t</sup> - 1

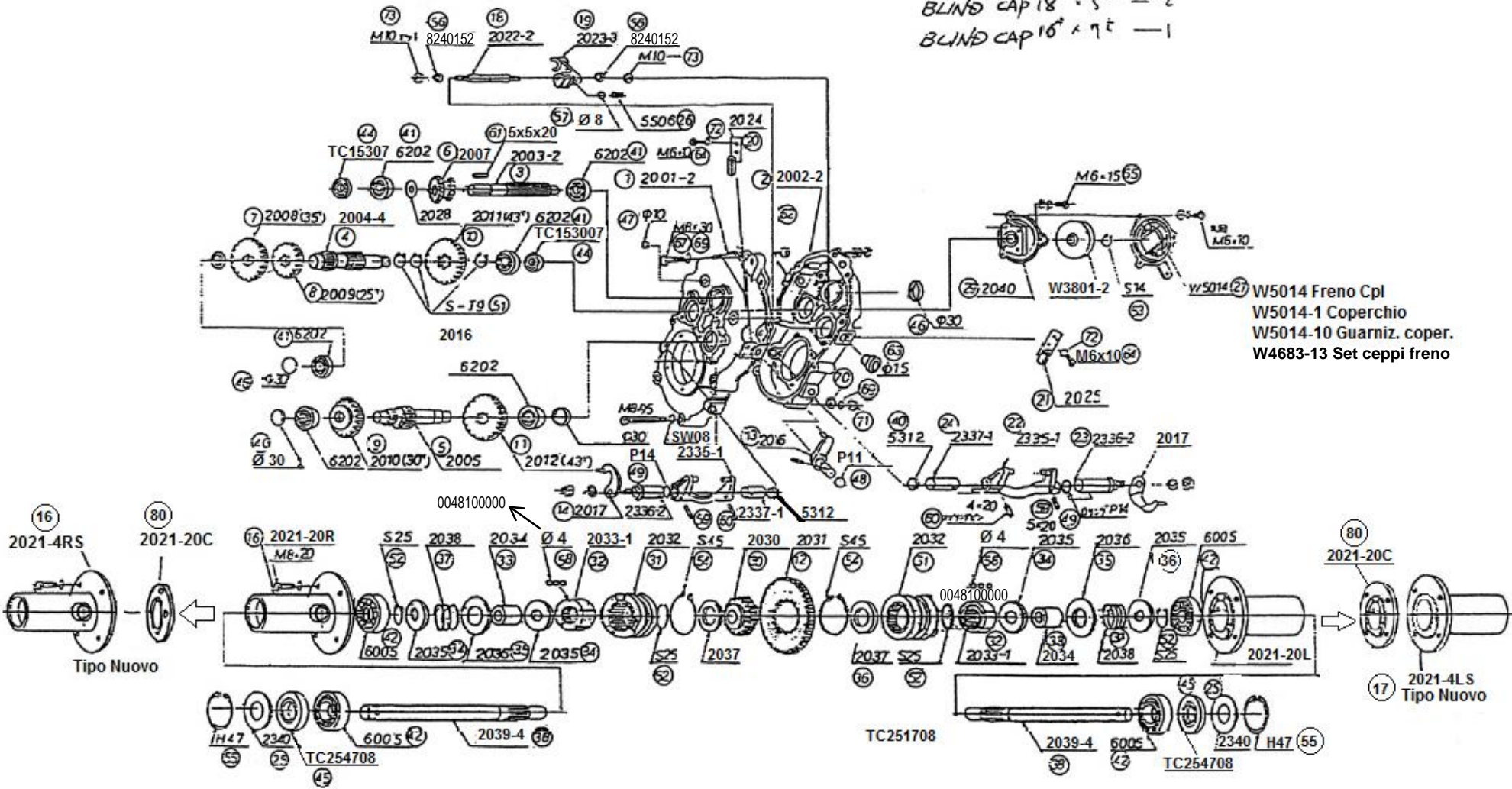

W5014 Freno Cpl  
 W5014-1 Coperchio  
 W5014-10 Guarniz. coper.  
 W4683-13 Set ceppi freno